

**Article Info**

Received: 10 Dec 2019 | Revised Submission: 20 Feb 2019 | Accepted: 28 Feb 2019 | Available Online: 25 Mar 2019

**Dependency of Output Signal to Noise Ratio on Output Power and Signal to Noise Ratio at Reference Path in the Adaptive Noise Cancellation Technique**

Jaspreet Singh Deo\*

**ABSTRACT**

In Adaptive noise cancelling method uses two inputs one is primary input and other is the reference input. A “primary” input the combination of main signal and noise whereas a “reference” input contains correlated noise within the primary signal. The difference of reference input from primary gives the noise free signal. It is verified that signal to noise ratio at reference path impact the signal to noise ratio at output, and by decreasing the signal to noise ratio at reference path increase in signal to noise ratio achieved. Also, by decreasing changing the output power a SIR changes immensely.

**Keywords:** Adaptive Filters; Couplers; Phase Shift; Reference Path; Primary Path.

**1.0 Introduction**

Basically filters are used to estimate an additive noise. To eliminate noise, the signal is passed through a filter. The domain of design these filters are called the optimal filtering. Filters used for this purpose can be adaptive or fixed[1]. A prior knowledge of signal and noise is required for designing fixed filters. Whereas the Adaptive filters, adjust own parameters for cancelling the noise. The adaptive filter makes use of reference input received from sensors which located in the noise field. This input is further is then subtracted from the primary signal or the main signal and eventually eliminates the noise. But if we use appropriate adaptive process of filtering and subtraction then noise reduction is achieved by minimum distortion of the signal [2]. By using adaptive noise cancellation we can achieve maximum cancellation of noise which may not be achieved by the direct cancelling[3].

**2.0 The Concept of Adaptive Noise Cancelling**

Fig. 1 shows that primary input contains main signal  $s$  and noise  $n_0$  uncorrelated with the signal is added using a noise source. The noise  $n_0$  is uncorrelated with the main signal  $s$ [4]. A noise  $n_1$  from the same noise source and correlated with  $n_0$  but uncorrelated with main signal is fed as reference

input to the canceller. The noise  $n_1$  is a close replica of  $n_0$  [5]. The reference input is subtracted from primary input to produce overall system output  $z = S + n_0$

**Fig 1: Adaptive Noise Cancellation**

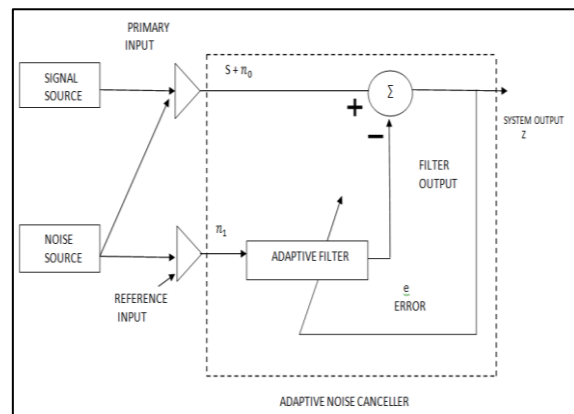

**3.0 Effect of Signal Components in the Reference Input**

In Figure-2 the adaptive noise canceller with reference input contains signal components and the primary and reference inputs carry the additive correlated noises[6]. If there is a signal component in the reference path of the system then when the subtraction of primary and reference inputs occurred

\*Department of Electronics and Communication Engineering, Khalsa College of Engineering and Technology, Amritsar, Punjab, India (E-mail: jasy9018@gmail.com)

then there is a large possibility that the signal in main path and the reference path remains correlated to each other and after subtraction they can cancel out each other and only noise remains left at the output as the overall output of the system. To overcome it a reasonable phase shift of the signals are recommended[7].

**Fig 2: Additive Noise in Priary and Refrence Path**

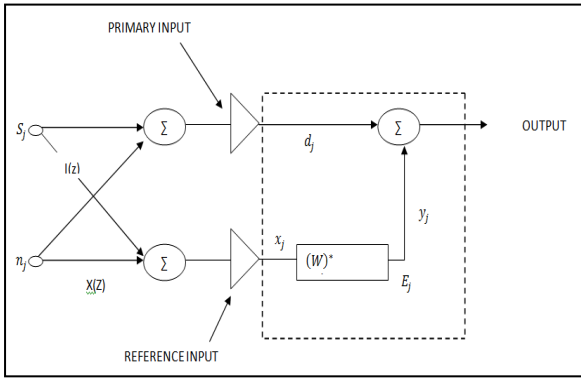

#### 4.0 Output Signal-to-Noise Density Ratio

The transfer function of the propagation path from the signal input to the noise canceller output is  $1 - I(Z)$  and that of the path from the noise input to the canceller output is  $1 - H(Z)$  [7]. The spectrum of the signal component in the output is thus

$$\delta_{ssout} = \delta_{ss}(z) |1 - I(Z)(W)^*|^2$$

and that of noise component

$$\delta_{nnout} = \delta_{nn}(z) |1 - H(Z)(W)^*|^2$$

The output signal-to-noise density ratio is thus

$$\rho_{out}(Z) = \frac{\delta_{nn}(z) |H(Z)|^2}{\delta_{ss}(z) |I(Z)|^2}$$

The output signal-to-noise density ratio can be conveniently expressed in terms of the signal-to-noise density ratio at the reference input  $\rho_{ref}$  as follows [8]. The spectrum of the signal component in the reference input is

$$\delta_{ssref} = \delta_{ss}(z) |I(Z)|^2$$

and that of noise component is similarly

$$\delta_{nnref} = \delta_{nn}(z) |H(Z)|^2$$

The signal-to-noise density ratio at the reference input is thus

$$\rho_{ref}(Z) = \frac{\delta_{ss}(z) |I(Z)|^2}{\delta_{nn}(z) |H(Z)|^2}$$

The output signal-to-noise density ratio is, therefore,

$$\rho_{out}(Z) = \frac{1}{\rho_{ref}(Z)}$$

It shows that, the signal-to-noise is the reciprocal of signal-to-noise density ratio at the reference input at all frequency.

#### 5.0 Signal Distortion at the Noise Canceller Output

The amount of signal distortion depends on the amount of the amount of signal propagated through the adaptive filter, and it is approximately equal to

$$\delta_{ss}(z) |I(Z)/H(Z)|^2$$

The combining of these components involves complex addition and it results in signal distortion[6]. The worst case happens when these two signal components are of opposite phase. The signal distortion is given by

$$D(z) \cong \rho_{ref}(Z) / \rho_{pri}(Z)$$

It shows that, with an unconstrained adaptive solution and mutually correlated noises at the primary and reference inputs, low signal distortion results from a high signal-to-noise density ratio at the primary input and a low signal-to-noise density ratio at the reference input[9].

#### 6.0 Output Noise

The output noise in terms of signal to noise density ratios is given by the ratio of signal to noise density at the reference input and primary input as given below

$$\delta_{output\ noise}(Z) \cong \delta_{nn}(z) |\rho_{ref}(Z)| |\rho_{pri}(Z)|$$

From this equation, it is clear that the output noise spectrum and input noise spectrum are dependent on each other.

Secondly, if the signal-to-noise density ratio at the reference input is low, the output noise will be low; that is, the smaller the signal component in the

reference input, the more perfectly noise will be cancelled[10].

Also, if the signal-to-noise density ratio in the primary input is low, the Output noise will be low.

**6.1 Dependence of output SIR on output power**

In this, it is proved with simulation on Advanced Design System that if the output power of Adaptive Interferer canceller (we are using interference instead of noise but rest of the concept is same) is decreased then the Output SIR would be increased [9]. Consider figure below

**Fig 3: Dependency of Output SIR on Output Power**

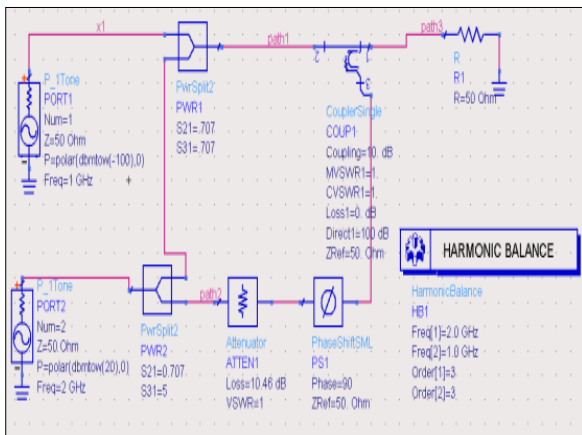

In this figure it is shown that there are two signal sources, Port 1 is for primary signal at 1 GHz frequency and Port 2 for interference at 2 GHz frequency. Port 1 is connected to power combiner PWR1. Port 2 is connected to power splitter PWR2, so that interference signal is divided into two parts. One part will remain in the reference path, whereas the other part is taken to primary path and added with the original signal with the help of PWR1. To provide 180 degree phase shift there is a phase shifter with 90 degree phase shift whereas other 90 will be done by the coupler used here in addition mode. We need opposite phase of signals on both paths so that there will be maximum cancellations. Attenuator is used to increase or decrease the interference signal level at

reference path. In this simulation, we vary the attenuator value and then check the values of signals at path3. We vary the attenuator value until we reduce the interferer value to some extent. Since in this experiment we want to check the dependence of output SIR and output power so our main aim is to vary the output power in every simulation no matter if we are getting maximum cancellation or not. Following details shows simulation results

The plot of these values are shown below

	SIR	output_Power
1	-16.241	1.34
2	-15.565	0.41
3	-15.163	-0.12
4	-14.71	-0.72
5	-14.193	-1.40
6	-12.905	-3.03

**Fig 4: Dependence of Output SIR on Output Power**

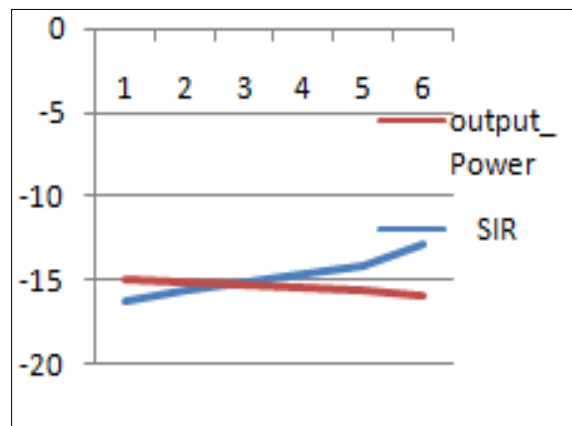

**7.0 Dependence of Output SIR on SIR at reference path.**

In this section, it is proved that SIR at reference path and at output path holds the following relationship

$$\rho_{out}(Z) = \frac{1}{\rho_{ref}(Z)}$$

This means both are inversely proportional to each other. To increase the SIR at output path we have to decrease SIR at reference path [10]. Consider the figure 5.

**Fig 5: Implementation of Adaptive Noise Cancellation Technique**

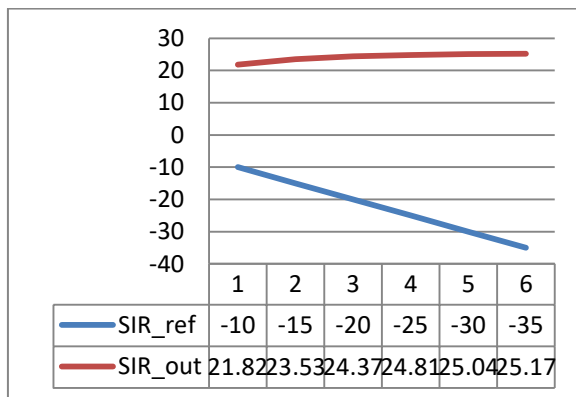
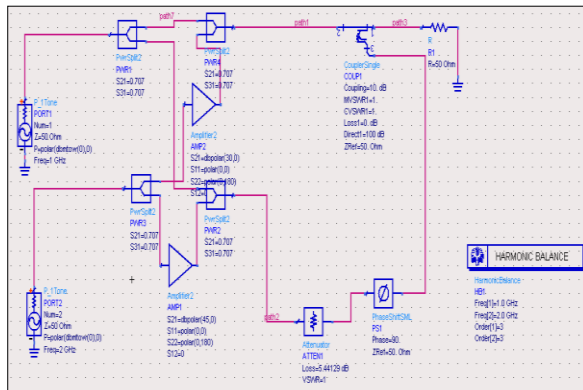

From this, we can notice that when SIR at reference path is -10 then the output SIR is 21.815 but when the reference SIR is decreasing the output SIR is increasing for example when reference SIR is decreased at -35 then the output SIR increased to 25.173 that means both SIRs are inversely proportional to each other. So we can say that if we have lesser signal component at the reference path then the cancellation will be moiré appropriate as the

less signal component will be canceled out and more correlated interference will be cancelled out

### 7.1 Conclusions

The additive noise introduced by Co-located Base stations produces distortion in the primary Signal. An adaptive cancellation system is used to overcome the interference and the performance improvement is verified by Advance Design System. It is confirmed that the output SIR is increased by decreasing the SIR of reference signal.

### References

- [1] F German, K Annamalai, M Young, MC Miller. Simulation and Data Management for Cosite Interference Prediction, Proc. IEEE International Symposium on Electromagnetic Compatibility, 7, 2010.
- [2] B Widrow, JR Glover, JM McCool, J Kaunitz, CS Williams, RH Hearn, JR Zeidler, EDongJr, RC Goodlin. Adaptive noise canceling: Principles and applications, Proc. IEEE, 63, 1975, 1692-1716.
- [3] JJ Gavan, MB Shulman. Effects of Desensitization on Mobile Radio System Performance, Part I: Quantitative Analysis, IEEE Transactions on Vehicular Technology, 33(4), 1984, 285-290,.
- [4] B Razavi, RF Microelectronics, Upper Saddle River, NJ: Prentice Hall, 1998.
- [5] B Razavi. Design Considerations for Direct-Conversion Receivers, IEEE Transactions on Circuit and Systems II: Analog and Digital Signal Processing, 44(6), 1997.
- [6] W Guthrie, D Hanson. Co-Location Interference Mitigation. White Paper. Netcom Inc., USA. <http://www.netcominc.com>, 6,2005

- [7] A Roussel, CWT Nicholls, JS Wight. Frequency Agile RF Feedforward Noise Cancellation System, Proc. IEEE Radio and Wireless Symposium, 2008.
- [8] S Kannangara, M Faulkner. Analysis of an Adaptive Wideband Duplexer With Double-Loop Cancellation, IEEE Transactions on Vehicular Technology, 56(4), 2007.
- [9] A Raghavan, E Gebara, EM Tentzeris, J Laskar. Analysis and Design of an Interference Canceller for Collocated Radios, IEEE Transactions on Microwave Theory and Techniques, 53(11), 2005.
- [10] B Widrow, JR Glover, JM McCool, J Kaunitz, CS Williams, RH Hearn, JR Zeidler, E Dong Jr, RC Goodlin. Adaptive noise canceling: Principles and applications, Proc. IEEE, 63, 1975, 1692-1716.